



World Health
Organization

WHEELCHAIR SERVICE TRAINING PACKAGE

Participant's Workbook

BASIC LEVEL



USAID
FROM THE AMERICAN PEOPLE



World Health
Organization

WHEELCHAIR SERVICE TRAINING PACKAGE

Participant's Workbook

BASIC LEVEL

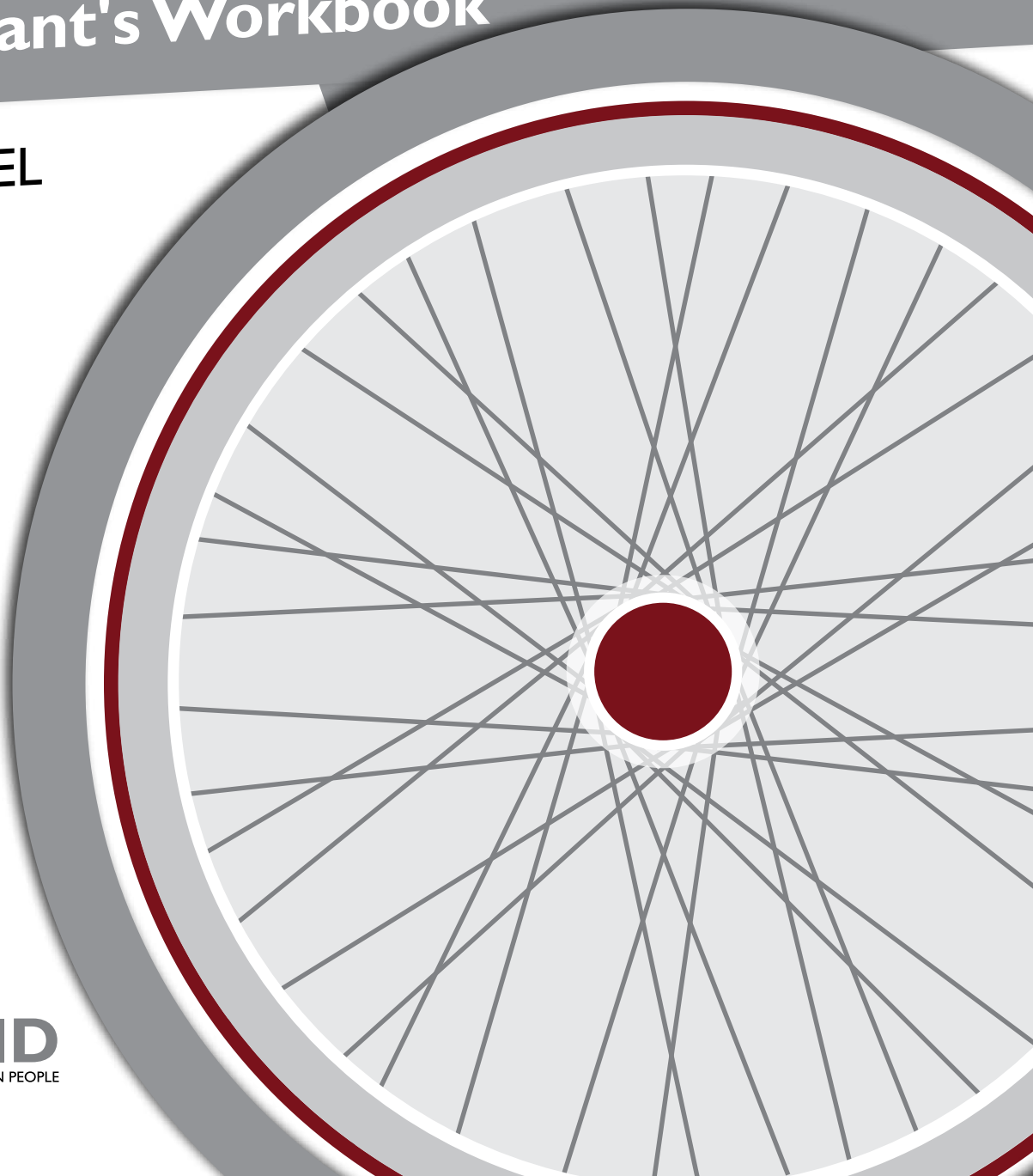

USAID
FROM THE AMERICAN PEOPLE

Contributors:

Editors:	Chapal Khasnabis and Kylie Mines
Authors:	Sarah Frost, Kylie Mines, Jamie Noon, Elsje Scheffler, and Rebecca Jackson Stoeckle
Peer reviewers:	Natasha Altin, Jo Armstrong, William Armstrong, Johan Borg, Jocelyn Campbell, Nelja Essaafi, Rob Horvath, Lauren Houpapa, Mohamed El Khadiri, R. Lee Kirby, Penny Knudson, Mark Kruizak, Bigboy Madzivanzira, Rob Mattingly, Cindy Mosher, Ritu Ghosh Moullick, Alana Officer, Andrew Rose, Allan Siekman, Sue Steel Smith, Michiel Steenbeek, Claude Tardif, and Isabelle Urseau
Illustrator:	Melissa Puust
Photo credits:	Chapal Khasnabis and Jesse Moss
Video credits:	Chapal Khasnabis, Amanda McBaine, and Jesse Moss
Pilot trainers:	Lauren Houpapa, Charles Kanyi, Norah Keitany, Seraphine Ongogo, M. Vennila Palanivelu Sama Raju, and Elsie Taloafiri
Financial support:	US Agency for International Development and Australian Agency for International Development
Partner organizations:	ASSERT East Timor, Association for the Physically Disabled of Kenya (APDK), Community Based Rehabilitation Unit of Solomon Islands Ministry of Health and Medical Services, Education Development Center (EDC), Handicap International, International Committee of the Red Cross (ICRC), International Society for Prosthetics and Orthotics (ISPO), Kilimanjaro Association of the Spinally Injured (KASI), Mobility India, Motivation Australia, Motivation Charitable Trust (Motivation), Motivation Romania, and Tanzania Training Centre for Orthopaedic Technologists (TATCOT)

WHO Library Cataloguing-in-Publication Data

Wheelchair service training package / edited by Chapal Khasnabis and Kylie Mines.

Contents: Trainer's manual, basic level—Reference manual for participants, basic level – Participant's workbook, basic level – Posters and slides, basic level.

Trainer's manual and slides available on DVD only.

1.Wheelchairs – standards. 2.Disabled persons – rehabilitation. 3.Teaching materials. I.Khasnabis, Chapal. II.Mines, Kylie. III.World Health Organization.

ISBN 978 92 4 150347 1 (package)

(NLM classification: WB 320)

ISBN 978 92 4 150348 8 (DVD)

© World Health Organization 2012

All rights reserved. Publications of the World Health Organization are available on the WHO web site (www.who.int) or can be purchased from WHO Press, World Health Organization, 20 Avenue Appia, 1211 Geneva 27, Switzerland (tel.: +41 22 791 3264; fax: +41 22 791 4857; e-mail: bookorders@who.int). Requests for permission to reproduce or translate WHO publications – whether for sale or for noncommercial distribution – should be addressed to WHO Press through the WHO web site (http://www.who.int/about/licensing/copyright_form/en/index.html).

The designations employed and the presentation of the material in this publication do not imply the expression of any opinion whatsoever on the part of the World Health Organization concerning the legal status of any country, territory, city or area or of its authorities, or concerning the delimitation of its frontiers or boundaries. Dotted lines on maps represent approximate border lines for which there may not yet be full agreement.

The mention of specific companies or of certain manufacturers' products does not imply that they are endorsed or recommended by the World Health Organization in preference to others of a similar nature that are not mentioned. Errors and omissions excepted, the names of proprietary products are distinguished by initial capital letters.

All reasonable precautions have been taken by the World Health Organization to verify the information contained in this publication. However, the published material is being distributed without warranty of any kind, either expressed or implied. The responsibility for the interpretation and use of the material lies with the reader. In no event shall the World Health Organization be liable for damages arising from its use.

Cover photo credits (clockwise, from top): Mile End Films /Jesse Moss; WHO /Chapal Khasnabis; Mile End Films / Jesse Moss; Panos /Dieter Telemans; WHO /Chapal Khasnabis.

Printed in Malta

Design by Inis Communication – www.iniscommunication.com

CONTENTS

1	Purpose
2	A.4: Sitting upright
4	A.6: Appropriate wheelchair
6	A.7: Cushions
7	A.8: Transfers
8	B.3: Assessment interview
13	B.4: Physical assessment
14	B.5: Prescription (selection) – wheelchair summaries
18	B.5: Prescription (selection) – selecting the right wheelchair size
20	B.7: Product (wheelchair) preparation
21	B.8: Cushion fabrication
23	B.11: User training
24	B.12: Maintenance and repairs
26	B.13: Follow up
30	B.14: Putting it all together

Name: _____

Purpose

The Basic Level training package is designed to support the training of personnel or volunteers to provide an appropriate manual wheelchair and cushion for girls, boys, women and men *who have mobility impairments but can sit upright without additional postural support.*

The purpose of the Participant's Workbook is to develop the skills and knowledge of personnel involved in wheelchair service delivery. The Participant's Workbook contains exercises which will help to test and develop participants' knowledge and skills. The Participant's Workbook contains material from lectures, slide presentations and the reference manual; it is intended that the participants will keep their copy of the workbook for future reference, if needed.

A.4: Sitting upright

- Look closely at each example of different postures.
- Write down how the posture is different from sitting upright.
- Think about the features of upright sitting from the front and side.

1.	Describe how this person's posture is different from "sitting upright".
	

2.	Describe how this person's posture is different from "sitting upright".
	

WHEELCHAIR

SERVICE TRAINING PACKAGE

<p>3.</p>	<p>Describe how this person's posture is different from "sitting upright".</p>
	

<p>4.</p>	<p>What problems could be caused by not sitting upright?</p>
	<ol style="list-style-type: none"> 1. 2. 3. 4. 5.

A.6: Appropriate wheelchair

- Read all the users' stories.
- Discuss which of the available wheelchairs would best suit each user's needs.
- List at least three reasons why the participants would recommend this wheelchair for the wheelchair user.
- Consider the wheelchair user's physical, environmental and lifestyle needs – and the features they need in a wheelchair.
- Write down your answers.

Bao	Which of the available wheelchairs would best suit Bao's needs? Why?
<p>Bao lives in a rural village. He has a bilateral above-knee amputation. Before his accident, he ran a shop on the road which runs past his village, selling general groceries. Now he can only reach the shop with help, as the pathway leading from his village to the road is long (almost 1 km), bumpy and often muddy. This has made it difficult for him and his family to keep the shop going.</p> <p>A long time ago Bao received a donated orthopaedic-style wheelchair. The chair is rusted and the seat upholstery has ripped. The front castor wheels are small and the rear wheel tyres are very thin and worn. He cannot push this wheelchair along the track from his hut to the village as the wheels dig into the path. He would like to be able to get to the shop on his own, so that he is not relying on his wife or others to help him.</p>	

Amanthi	Which of the available wheelchairs would best suit Amanthi's needs? Why?
<p>Amanthi is 24 and lives with her family in a small town. She was involved in a car accident when she was 18, and became a paraplegic. Amanthi recently had a pressure ulcer, which took six months to heal.</p> <p>Amanthi has an orthopaedic wheelchair, but it does not give her good support and she gets very tired in it. It does not have a cushion. She thinks this is probably why she developed a pressure sore.</p> <p>Amanthi has been invited to attend a secretarial course and wants to go. However, she is worried that she will not be able to sit up all day in her current wheelchair.</p>	



WHEELCHAIR

SERVICE TRAINING PACKAGE

Phillip	Which of the available wheelchairs would best suit Phillip's needs? Why?
<p>Phillip is 62 years old and lives in a small island community. Six months ago he had a stroke. He returned to his home after one month in a hospital without a wheelchair. He has been lying in bed or sitting in a chair on the veranda of his home.</p> <p>Phillip cannot move his left arm or left leg. However, he is getting stronger each day and can now stand upright with the help from a family member. He is exercising his right arm, and is very keen to have a wheelchair so that he can be more mobile and less reliant on his family.</p> <p>He wants to be able to move around his small home which is all on one level, and around his local community. The terrain is very sandy. One of his grandsons owns a car and says that he will take him out if he has a wheelchair.</p>	



Sabina	Which of the available wheelchairs would best suit Sabina's needs? Why?
<p>Sabina is 56 years old and lives in a small island community. After the birth of her fourth child many years ago, she lost most of the use of her legs. She can stand a little, but she cannot walk. She has never had a wheelchair.</p> <p>Sabina lives in a small village near the sea – and the surface around her home and the village is rough and sandy. She spends her time helping to care for her grandchildren, cooking and weaving. There is no room inside her home for a wheelchair, but it can be stored underneath, as her home is on stilts (columns).</p>	

Which of the available wheelchairs would be most suitable for your environment and why?

- 1.
- 2.
- 3.
- 4.
- 5.

A.7: Cushions

- Practise checking the pressure under each seat bone (left and right) of each person in the group.
- Make sure that everyone in the group has a turn being tested, and testing.
- Record the level of pressure for each person in the group in the table below.

Check pressure under seat bones for all wheelchair users at risk of developing a pressure sore.		
A		Before you start, explain the test to the wheelchair user.
B		Ask the wheelchair user to push up or lean forward to allow you to place your finger tips under their left or right seat bones (palm up).
C		Ask the wheelchair user to sit back down on your fingers. He/she should sit normally, face forward, and place the hands on the thighs.
D	Identify the pressure: Level 1 = safe: Finger tips can wriggle up and down 5 mm or more. Level 2 = warning: Finger tips cannot wriggle, but can easily slide out. Level 3 = unsafe: Finger tips are squeezed firmly. It is difficult to slide fingers out.	
E	Repeat under the second seat bone.	

Record the level of pressure for each person in the group in the table below.

	Left seat bone	Right seat bone
Person 1	Level 1: <input type="checkbox"/> Level 2: <input type="checkbox"/> Level 3: <input type="checkbox"/>	Level 1: <input type="checkbox"/> Level 2: <input type="checkbox"/> Level 3: <input type="checkbox"/>
Person 2	Level 1: <input type="checkbox"/> Level 2: <input type="checkbox"/> Level 3: <input type="checkbox"/>	Level 1: <input type="checkbox"/> Level 2: <input type="checkbox"/> Level 3: <input type="checkbox"/>
Person 3	Level 1: <input type="checkbox"/> Level 2: <input type="checkbox"/> Level 3: <input type="checkbox"/>	Level 1: <input type="checkbox"/> Level 2: <input type="checkbox"/> Level 3: <input type="checkbox"/>
Person 4	Level 1: <input type="checkbox"/> Level 2: <input type="checkbox"/> Level 3: <input type="checkbox"/>	Level 1: <input type="checkbox"/> Level 2: <input type="checkbox"/> Level 3: <input type="checkbox"/>

A.8: Transfers

- Read the users' stories.
- Discuss for each wheelchair user the transfer method which will best suit them and why.
- Write down your answers.

<p>Faridah</p>	<p>Which transfer method would be most appropriate for Faridah? Why?</p>
<p>Faridah is 60 years old. She was referred to the wheelchair service by the local hospital. She has recently had a stroke, and needs a wheelchair as she cannot walk.</p> <p>Faridah can stand up a little and take her own weight. However she is very unsteady on her feet. Faridah lives with her daughter and her family.</p> <p>Her daughter does not work and is able to help her mother at home. She has a four-wheel wheelchair with swing-away footrests.</p>	
<p>Jose</p>	<p>Which transfer method would be most appropriate for Jose? Why?</p>
<p>Jose is 45 years old and has been using a wheelchair for 10 years. He has a bilateral above-knee amputation and works in a radio repair workshop in the local market.</p> <p>Jose has come to the wheelchair service to get a new wheelchair as his old one is very worn.</p>	
<p>Tahir</p>	<p>Which transfer method would be most appropriate for Tahir? Why?</p>
<p>Wheelchair user Tahir is 14 years old and has recently been referred for a wheelchair after falling from a tree and having a spinal cord injury.</p> <p>Tahir has good use of his arms but he is not yet very strong. He cannot use his legs at all.</p>	

B.3: Assessment interview

- Each person in the group is to select and read one story – and role play that wheelchair user. When you are interviewed, use the information from the story to answer the interview questions as well as you can.
- **Do not read the user's story out loud to the rest of your group and do not read anyone else's story.**
- Take it in turns to interview one another and complete the assessment forms on the following pages.

Felicia is an elderly woman with severe arthritis. She has pain in her arms, hands and legs. She is unable to walk more than a few steps because of the pain and finds it difficult to look after herself.

Felicia has attended the assessment with her daughter. She lives in a small town and her house has three steps at the front entrance. She does not have any health problems apart from the arthritis. She used to go to church regularly but is no longer able to do so. She uses a western-style toilet in her home.

Her family do not own a car, and rely on public transport. To come to the assessment, the family hired a taxi. However, this is expensive for them. She does not currently have a wheelchair.

Anton has polio. He is 26 and lives in a small town. He is studying computer skills and wants very much to start his own business in the future. He has attended the assessment with his wife.

A long time ago, Anton received a donated orthopaedic-style wheelchair. The chair is rusted and the seat upholstery has ripped. The front castors wheels are small and thin. The rear wheel tyres are very thin and worn. The wheelchair is uncomfortable and difficult to push. Anton uses the same toilet as his family.

The paths in the town are very rough and his wheelchair gets stuck often. However, Anton would like to be able to travel from his home to the vocational training centre on his own. The distance is about 1½ km. Right now he needs help from his younger brother – who cannot always take him on time.

Chantou is a 13 year old girl. She lost both of her legs (above the knee) during an earthquake. She lives with her family in an apartment in a nearby town. She has attended the assessment with her mother and older sister. She has a wheelchair which was donated to her. It is an adult size orthopaedic-style wheelchair. The wheelchair is too big for Chantou. She has to reach up over the armrests to reach the push rims. This is difficult for her. The backrest is also very high and there is no cushion.

Chantou would like to go back to school, but she feels physically uncomfortable in the wheelchair. She is embarrassed that she cannot move herself around. She would like a wheelchair that she can push herself, and which gives her more support. She says she would use the school bus if her wheelchair could go with her.

WHEELCHAIR

SERVICE TRAINING PACKAGE

Interview the person who is role-playing a wheelchair user in your group and complete the assessment form below.

Assessor's name: _____ Date of assessment: _____

Information about the wheelchair user

Name: _____ Number: _____

Age: _____ Male Female

Phone no.: _____ Address: _____

Goals: _____

Physical condition

Cerebral palsy Polio Spinal cord injury Stroke Frail
Spasms or uncontrolled movements

Amputation: R above knee R below knee L above knee L below knee
Bladder problems Bowel problems

If the wheelchair user has bladder or bowel problems, are these managed? Yes No

Others: _____

Lifestyle and environment

Describe where the wheelchair user will use their wheelchair:

Distance travelled per day: Up to 1km 1–5km More than 5km

Hours per day using wheelchair?

Less than 1 1–3 3–5 5–8 More than 8 hours

When out of the wheelchair, where does the user sit or lie down and how (posture and the surface?)

Transfer: Independent Assisted Standing Non-standing Lifted Other

Type of toilet (if transferring to a toilet): Squat Western Adapted

Does the wheelchair user often use public/private transport? Yes No

If yes, then what kind: Car Taxi Bus Other _____

Existing wheelchair (if a person already has a wheelchair)

Does the wheelchair meet the user's needs? Yes No

Does the wheelchair meet the user's environmental conditions? Yes No

Does the wheelchair provide proper fit and postural support? Yes No

Is the wheelchair safe and durable?
(Consider whether there is a cushion) Yes No

Does the cushion provide proper pressure relief
(if user has pressure sore risk)? Yes No

Comments: _____

*If yes to all questions, the user may not need a new wheelchair. If no to any of these questions, the user needs a different wheelchair or cushion; **or** the existing wheelchair or cushion needs repair or modifications.*

WHEELCHAIR

SERVICE TRAINING PACKAGE

Interview the person who is role-playing a wheelchair user in your group and complete the assessment form below.

Assessor's name: _____ Date of assessment: _____

Information about the wheelchair user

Name: _____ Number: _____

Age: _____ Male Female

Phone no.: _____ Address: _____

Goals: _____

Physical condition

Cerebral palsy Polio Spinal cord injury Stroke Frail

Spasms or uncontrolled movements

Amputation: R above knee R below knee L above knee

L below knee Bladder problems Bowel problems

If the wheelchair user has bladder or bowel problems, are these managed? Yes No

Others: _____

Lifestyle and environment

Describe where the wheelchair user will use their wheelchair:

Distance travelled per day: Up to 1km 1–5km More than 5km

Hours per day using wheelchair?

Less than 1 1–3 3–5 5–8 More than 8 hours

When out of the wheelchair, where does the user sit or lie down and how (posture and the surface?)

Transfer: Independent Assisted Standing Non-standing Lifted Other

Type of toilet (if transferring to a toilet): Squat Western Adapted

Does the wheelchair user often use public/private transport? Yes No

If yes, then what kind: Car Taxi Bus Other _____

Existing wheelchair (if a person already has a wheelchair)

Does the wheelchair meet the user's needs? Yes No

Does the wheelchair meet the user's environmental conditions? Yes No

Does the wheelchair provide proper fit and postural support? Yes No

Is the wheelchair safe and durable?
(Consider whether there is a cushion) Yes No

Does the cushion provide proper pressure relief
(if user has pressure sore risk)? Yes No

Comments: _____

*If yes to all questions, the user may not need a new wheelchair. If no to any of these questions, the user needs a different wheelchair or cushion; **or** the existing wheelchair or cushion needs repair or modifications.*

B.4: Physical assessment

Each member of your group should measure the others in the group. Record the measurements below. Write the name of the person measuring in the table as well.

1. Name of the wheelchair user: _____

		Measurer 1:	Measurer 2:
	Body Measurement	Measurement (mm)	Measurement (mm)
A	Hip width		
B	Seat depth	L	
		R	
C	Calf length	L	
		R	
D	Bottom of rib cage		
E	Bottom of shoulder blade		

2. Name of the wheelchair user: _____

		Measurer 1:	Measurer 2:
	Body Measurement	Measurement (mm)	Measurement (mm)
A	Hip width		
B	Seat depth	L	
		R	
C	Calf length	L	
		R	
D	Bottom of rib cage		
E	Bottom of shoulder blade		

3. Name of the wheelchair user: _____

		Measurer 1:	Measurer 2:
	Body Measurement	Measurement (mm)	Measurement (mm)
A	Hip width		
B	Seat depth	L	
		R	
C	Calf length	L	
		R	
D	Bottom of rib cage		
E	Bottom of shoulder blade		

B.5: Prescription (selection) – wheelchair summaries

- Complete the wheelchair summary sheet for the wheelchair assigned to you by the trainer.
- To complete the form you will need to:
 - look carefully at the wheelchair;
 - look at any written information about the chair (if available);
 - take measurements (if not available in written information), which may require adjusting the wheelchair to the minimum and maximum range of some adjustable features.

Complete the wheelchair summary for any other locally available wheelchair.

Name of wheelchair:			
Manufacturer/supplier:			
Sizes available:		Overall weight:	

Description:

Frame:	Folding	<input type="checkbox"/>	Fixed or rigid	<input type="checkbox"/>	Frame length(mm)	
Backrest:	Slung/canvas	<input type="checkbox"/>	Solid	<input type="checkbox"/>	Tension adjustable	<input type="checkbox"/>
Seat:	Slung/canvas	<input type="checkbox"/>	Solid	<input type="checkbox"/>	Tension adjustable	<input type="checkbox"/>
Cushion:	No cushion	<input type="checkbox"/>	Flat foam	<input type="checkbox"/>	Foam-contoured	<input type="checkbox"/>
Footrests:	Swing-away	<input type="checkbox"/>	Fixed	<input type="checkbox"/>	Other:	
Castor wheels:			Diameter:			
			Width:			
Rear wheels:	Pneumatic	<input type="checkbox"/>	Diameter:		Push rims	<input type="checkbox"/>
	Solid	<input type="checkbox"/>	Width:		Adjustable axle	<input type="checkbox"/>
	Solid inner tube	<input type="checkbox"/>			Removable	<input type="checkbox"/>
Brakes:	Short lever	<input type="checkbox"/>	Long lever	<input type="checkbox"/>	Other:	
Armrests:	Fixed	<input type="checkbox"/>	Removable	<input type="checkbox"/>	Other:	
Push handles:	Push handles	<input type="checkbox"/>				
Extra parts/ options:	Calf strap	<input type="checkbox"/>	Anti-tip bars	<input type="checkbox"/>	Tray	<input type="checkbox"/>
	Other:					



WHEELCHAIR

SERVICE TRAINING PACKAGE

Measurements, adjustment options and range of adjustment:

	Measurement (if the wheelchair is available in different sizes, list all sizes)	Is this adjustable?		Range of adjustment (adjustment range that is possible for this chair)
		Yes	No	
Seat width:		<input type="checkbox"/>	<input type="checkbox"/>	
Seat depth:		<input type="checkbox"/>	<input type="checkbox"/>	
Seat height:		<input type="checkbox"/>	<input type="checkbox"/>	
Backrest height:		<input type="checkbox"/>	<input type="checkbox"/>	
Backrest angle:		<input type="checkbox"/>	<input type="checkbox"/>	
Footrests height:		<input type="checkbox"/>	<input type="checkbox"/>	
Footrests angle:		<input type="checkbox"/>	<input type="checkbox"/>	
Push handles height:		<input type="checkbox"/>	<input type="checkbox"/>	
Frame length:		<input type="checkbox"/>	<input type="checkbox"/>	
Wheelbase length:		<input type="checkbox"/>	<input type="checkbox"/>	

Complete the wheelchair summary for any other locally available wheelchair.

Name of wheelchair:			
Manufacturer/supplier:			
Sizes available:		Overall weight:	

Description:

Frame:	Folding	<input type="checkbox"/>	Fixed/rigid	<input type="checkbox"/>	Frame length(mm)	
Backrest:	Slung/canvas	<input type="checkbox"/>	Solid	<input type="checkbox"/>	Tension adjustable	<input type="checkbox"/>
Seat:	Slung/canvas	<input type="checkbox"/>	Solid	<input type="checkbox"/>	Tension adjustable	<input type="checkbox"/>
Cushion:	No cushion	<input type="checkbox"/>	Flat foam	<input type="checkbox"/>	Foam-contoured	<input type="checkbox"/>
Footrests:	Swing-away	<input type="checkbox"/>	Fixed	<input type="checkbox"/>	Other:	
Castor wheels:			Diameter:			
			Width:			
Rear wheels:	Pneumatic	<input type="checkbox"/>	Diameter:		Push rims	<input type="checkbox"/>
	Solid	<input type="checkbox"/>	Width:		Adjustable axle	<input type="checkbox"/>
	Solid inner tube	<input type="checkbox"/>			Removable	<input type="checkbox"/>
Brakes:	Short lever	<input type="checkbox"/>	Long lever	<input type="checkbox"/>	Other:	
Armrests:	Fixed	<input type="checkbox"/>	Removable	<input type="checkbox"/>	Other:	
Push handles:	Push handles	<input type="checkbox"/>				
Extra parts/ options:	Calf strap	<input type="checkbox"/>	Anti-tip bars	<input type="checkbox"/>	Tray	<input type="checkbox"/>
	Other:					

Measurements, adjustment options and range of adjustment:

	Measurement (if the wheelchair is available in different sizes list all sizes)	Is this adjustable?		Range of adjustment (adjustment range that is possible for this chair)
		Yes	No	
Seat width:		<input type="checkbox"/>	<input type="checkbox"/>	
Seat depth:		<input type="checkbox"/>	<input type="checkbox"/>	
Seat height:		<input type="checkbox"/>	<input type="checkbox"/>	
Backrest height:		<input type="checkbox"/>	<input type="checkbox"/>	
Backrest angle:		<input type="checkbox"/>	<input type="checkbox"/>	
Footrests height:		<input type="checkbox"/>	<input type="checkbox"/>	
Footrests angle:		<input type="checkbox"/>	<input type="checkbox"/>	
Push handles height:		<input type="checkbox"/>	<input type="checkbox"/>	
Frame length:		<input type="checkbox"/>	<input type="checkbox"/>	
Wheelbase length:		<input type="checkbox"/>	<input type="checkbox"/>	

WHEELCHAIR

SERVICE TRAINING PACKAGE

Complete the wheelchair summary for any other locally available wheelchair.

Name of wheelchair:			
Manufacturer/ supplier:			
Sizes available:		Overall weight:	

Description:

Frame:	Folding	<input type="checkbox"/>	Fixed/rigid	<input type="checkbox"/>	Frame length(mm)	
Backrest:	Slung/canvas	<input type="checkbox"/>	Solid	<input type="checkbox"/>	Tension adjustable	<input type="checkbox"/>
Seat:	Slung/canvas	<input type="checkbox"/>	Solid	<input type="checkbox"/>	Tension adjustable	<input type="checkbox"/>
Cushion:	No cushion	<input type="checkbox"/>	Flat foam	<input type="checkbox"/>	Foam-contoured	<input type="checkbox"/>
Footrests:	Swing-away	<input type="checkbox"/>	Fixed	<input type="checkbox"/>	Other:	
Castor wheels:			Diameter:			
			Width:			
Rear wheels:	Pneumatic	<input type="checkbox"/>	Diameter:		Push rims	<input type="checkbox"/>
	Solid	<input type="checkbox"/>	Width:		Adjustable axle	<input type="checkbox"/>
	Solid inner tube	<input type="checkbox"/>			Removable	<input type="checkbox"/>
Brakes:	Short lever	<input type="checkbox"/>	Long lever	<input type="checkbox"/>	Other:	
Armrests:	Fixed	<input type="checkbox"/>	Removable	<input type="checkbox"/>	Other:	
Push handles:	Push handles	<input type="checkbox"/>				
Extra parts/ options:	Calf strap	<input type="checkbox"/>	Anti-tip bars	<input type="checkbox"/>	Tray	<input type="checkbox"/>
	Other:					

Measurements, adjustment options and range of adjustment:

	Measurement (if the wheelchair is available in different sizes list all sizes)	Is this adjustable?		Range of adjustment (adjustment range that is possible for this chair)
		Yes	No	
Seat width:		<input type="checkbox"/>	<input type="checkbox"/>	
Seat depth:		<input type="checkbox"/>	<input type="checkbox"/>	
Seat height:		<input type="checkbox"/>	<input type="checkbox"/>	
Backrest height:		<input type="checkbox"/>	<input type="checkbox"/>	
Backrest angle:		<input type="checkbox"/>	<input type="checkbox"/>	
Footrests height:		<input type="checkbox"/>	<input type="checkbox"/>	
Footrests angle:		<input type="checkbox"/>	<input type="checkbox"/>	
Push handles height:		<input type="checkbox"/>	<input type="checkbox"/>	
Frame length:		<input type="checkbox"/>	<input type="checkbox"/>	
Wheelbase length:		<input type="checkbox"/>	<input type="checkbox"/>	

B.5: Prescription (selection) – selecting the right wheelchair size

For each of the examples below:

- work out the ideal wheelchair size *and*
- select from the wheelchairs available the best size match for that user.

(Assume that the wheelchair cushion the user would use in both cases is 50 mm high.)

1	Body Measurement	Measurement (mm)	Change body measurement to ideal wheelchair size	Wheelchair measurement
A	Hip width	380 mm	Hip width = seat width	
B	Seat depth	L	B less 30–60 mm = seat depth (if lengths are different, use shortest)	
		R		
C	Calf length	L	= top of seat cushion to footrests height <i>or</i>	
		R	= top of seat cushion to floor for foot propelling	

WHEELCHAIR

SERVICE TRAINING PACKAGE

D	Bottom of rib cage		= top of seat cushion to top of backrest	
E	Bottom of shoulder blade	380 mm	(measure D or E – depending on the user's need)	

Ideal wheelchair size for this wheelchair user:	Seat width:	
	Seat depth:	
	Backrest height:	
From the available wheelchairs, which wheelchair and size best fits the user?		

2	Body Measurement	Measurement (mm)	Change body measurement to ideal wheelchair size	Wheelchair measurement
A	Hip width	420 mm	Hip width = seat width	
B	Seat depth	L	460 mm	B less 30–60 mm = seat depth (if lengths are different, use shortest)
		R	460 mm	
C	Calf length	L	360 mm	= top of seat cushion to footrests height <i>or</i> = top of seat cushion to floor for foot propelling
		R	360 mm	
D	Bottom of ribcage	260 mm	= top of seat cushion to top of backrest	
E	Bottom of shoulder blade	–	(measure D or E – depending on the user's need)	

Ideal wheelchair size for this wheelchair user:	Seat width:	
	Seat depth:	
	Backrest height:	
From the available wheelchairs, which wheelchair and size best fits the user?		

B.7: Product (wheelchair) preparation

Checklist: Is the wheelchair safe and ready to use?

Name of wheelchair service:			
Name of wheelchair user:			
Wheelchair type:		Wheelchair serial number:	

Whole wheelchair	
There are no sharp edges	<input type="checkbox"/>
No parts are damaged or scratched	<input type="checkbox"/>
The wheelchair travels in a straight line	<input type="checkbox"/>
Front castor wheels	
Spin freely	<input type="checkbox"/>
Spin without touching the fork	<input type="checkbox"/>
Bolts are tight	<input type="checkbox"/>
Front castor barrels	
Castor fork spins freely	<input type="checkbox"/>
Rear wheels	
Spin freely	<input type="checkbox"/>
Axle bolts are tight	<input type="checkbox"/>
Tyres inflated correctly (with thumb pressure, wheel can be depressed less than 5 mm)	<input type="checkbox"/>
Push rims are secure	<input type="checkbox"/>
Brakes	
Function properly	<input type="checkbox"/>
Footrests	
Footrests are securely attached	<input type="checkbox"/>
Frame	
For a folding wheelchair – the wheelchair folds and unfolds easily	<input type="checkbox"/>
For a wheelchair with fold-down backrest – the backrest folds and unfolds easily	<input type="checkbox"/>
Cushion	
The cushion is in the cover correctly	<input type="checkbox"/>
The cushion is sitting on the wheelchair correctly	<input type="checkbox"/>
The cushion cover fabric is tight but not too tight	<input type="checkbox"/>
If the wheelchair has a solid seat: the cushion fully covers the solid seat	<input type="checkbox"/>

Name of person who has checked the wheelchair:			
Signature:		Date:	

B.8: Cushion fabrication

Seat bones well dimensions

Calculate the correct seat bones well dimensions for each of the wheelchair users in the table below:

	Width	Depth	Height
Adult wheelchair user – 360 mm seat width			
Adult wheelchair user – 460 mm seat width			
Child wheelchair user – 280 mm seat width			

Cushion fabrication

- Work with a partner.
- Follow the instructions below to make a cushion. Ask trainers if you have any questions.

I. Mark out the cut lines

- Use a piece of firm foam 400 mm x 400 mm x 50 mm.
- The centre of the seat bones well must be on the centre line of the cushion.
- For this size cushion, the seat bones well should measure 200 mm x 200 mm x 35 mm.
- Draw the cut lines with a dark coloured marker on all six sides of the base foam.

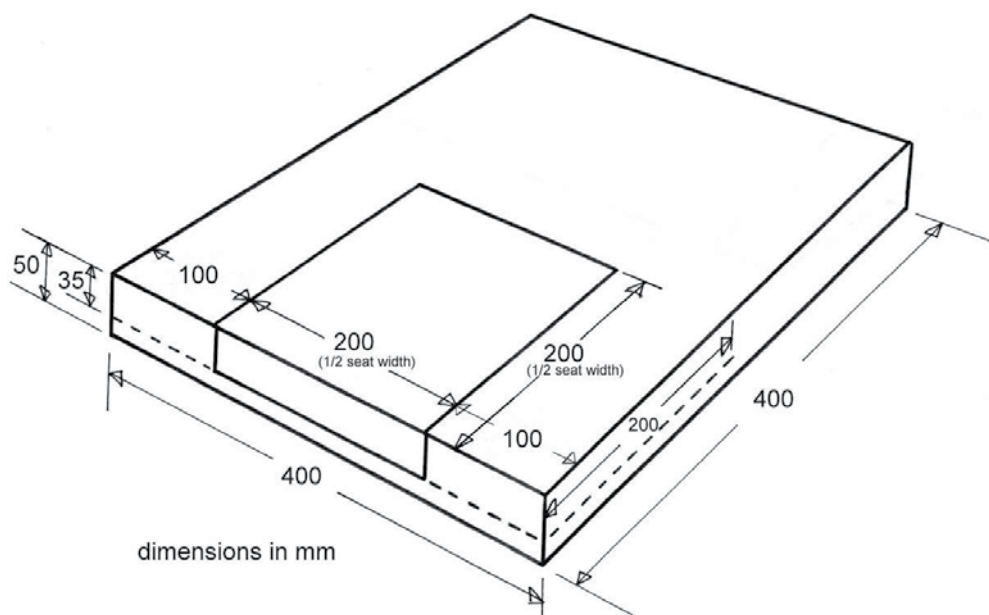

2. Cut out the well for seat bones: Use a sharpened hacksaw blade or long knife. Use long slow strokes, cutting mostly when pulling to improve control.

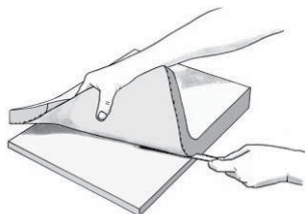

- First cut through the back of the cushion to the depth of the seat bones well.



- Then slice out the "seat bones well".

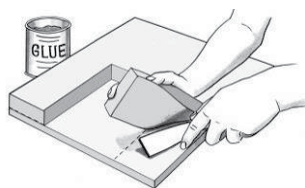

- Glue back into place the two "flaps" left on either side of the seat bones well.

3. Cut off the corners inside the seat bones well

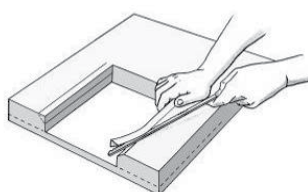

4. For a slung seat cushion: make an angled cut (bevel) on both sides of the base (underside)

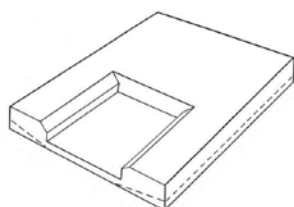

- Mark out as shown and cut.
- This cut helps the base of the cushion to match the shape of a slung wheelchair seat.

5. Place the top foam layer on top of the cushion

- Both the base and top layer are placed in the cushion cover together.
- The two layers do not need to be glued together.
- If the top layer becomes soiled or worn out, it can be washed and dried or replaced.
- A lift can be added within the cover (on top of the base layer and under the comfort layer) to increase the depth of the pelvic well.

B.II: User training

- Read the users' stories.
- Identify **at least three skills** from the wheelchair user training checklist that will be very important for the wheelchair user to know before leaving the wheelchair service with the new wheelchair.
- Practise teaching **one skill** to the wheelchair user (take it in turns to be the wheelchair service personnel, instructor and family member). Remember to use the good teaching methods discussed in the session.

Moses	What skills do you think Moses could benefit from learning?
<p>Moses is 23 years old. He fell from the back of a truck two years ago and became paraplegic. He spent one year in the hospital and then returned to his home village with an old donated wheelchair. The wheelchair broke very quickly and he was unable to move around. He developed a pressure sore which has now healed.</p> <p>Moses has just received a new wheelchair with a pressure relief cushion through the wheelchair service. This wheelchair is designed to go over rough ground. He is very excited about going home with this wheelchair and is hopeful that he will be more independent.</p>	

Sian	What skills do you think Sian could benefit from learning?
<p>Sian is 40 years old and has a bilateral above knee amputation. He has been a wheelchair user for 20 years and has had five wheelchairs over that time. He finds that the wheelchairs he has break down quickly.</p> <p>He is very active and works in a local shop. He travels from his home to the shop every day – on rough, bumpy and often muddy paths. He demonstrated for the wheelchair service personnel how he can do wheelies.</p> <p>He has just been prescribed a new wheelchair. He is hoping that this wheelchair will last longer than his last one, which broke down after six months.</p>	

Zoe	What skills do you think Zoe could benefit from learning?
<p>Zoe is 16 years old. She had polio as a young girl, and now cannot walk. She is very shy, and has not been to school. Her mother has given her lessons at home and she can read and write well. She has just received a new wheelchair and has shown the wheelchair service personnel how she can transfer easily into and out of the chair.</p> <p>Zoe is interested in attending a local vocational school – however, she does not think that she can manage getting to the school and back. There are a few steps into the school building. She is also worried about how she would go to the toilet while at the school.</p>	

B.12: Maintenance and repairs

Maintenance:

- Identify what can be done to care for a wheelchair and cushion at home

1. _____

2. _____

3. _____

4. _____

5. _____

6. _____

Repairs:

- Look closely at each wheelchair available for the training purpose.
- Identify which needs repairing (if any), and suggest how these repairs could be made in your location.

Wheelchair A

What needs repairing?	How can this be repaired in your location?

Wheelchair B

What needs repairing?	How can this be repaired in your location?

Wheelchair C

What needs repairing?	How can this be repaired in your location?

B.13: Follow up

- Read each user's story.
- Discuss what actions should be taken.
- Complete a follow up form for each user, including noting any actions to be taken.

Hala

Hala lives at home with her grown up daughter and her family. She received a wheelchair through the wheelchair service six months ago. She had a stroke just over a year ago, and is unable to walk. When she received her wheelchair, she learnt how to do a standing transfer with help from her daughter. She said she wanted a wheelchair so that she could be more help in the home, and be able to go to church.

At the follow up visit, Hala said that she has not left her house for some months. The path to her house is quite rough, and there is a step leading up to the house from the path. She is, however, using the wheelchair at home, and has been able to help her daughter by helping to look after her grandchildren. She sits upright in the wheelchair and the wheelchair is in good repair. She was able to transfer from the chair herself without her daughter's help.

Daarun

Daarun has a spinal cord injury. He works in a radio repair workshop in the local market. He received his wheelchair and pressure relief cushion two years ago. At the follow up visit, he said that he uses his wheelchair every day to get to and from the market. He does not have any pressure sores.

Daarun has had two flat tyres and has repaired them himself. When checking the wheelchair, the service worker notices that the spokes are loose and two bolts are missing on the seat base. The soft foam on his cushion has become very flat. He sits well in the wheelchair and says that he is very satisfied with the chair.

Talha

Talha is 10 years old. He has mild cerebral palsy and goes to the local school. He was prescribed a four wheel wheelchair with a postural support cushion one year ago.

At the follow up visit, Talha said that he uses his wheelchair every day to get to school. His father pushes him as he does not have the strength to push himself. The wheelchair is in good repair. His father says that he has repaired the tyre once.

The wheelchair service worker notices that Talha has grown, and his legs are now not properly supported by the wheelchair seat as the footrests are too high for him.

Wheelchair follow up form

This form is for recording information from a follow up visit.

1. Wheelchair user information

Wheelchair user name: Hala _____ Number: _____

Date of fitting: _____ Date of follow up: _____

Name of person carrying out follow up: _____

Follow up carried out at: User's home Wheelchair service centre Other: _____

2. Interview

**Record action
to be taken:**

Are you using your wheelchair as much as you would like?	Yes <input type="checkbox"/> No <input type="checkbox"/>	
If no – why not?		
Do you have any problems using your wheelchair?	Yes <input type="checkbox"/> No <input type="checkbox"/>	
If yes – what are the problems?		
Do you have any questions about using your wheelchair?	Yes <input type="checkbox"/> No <input type="checkbox"/>	
If yes – what questions? Is further training needed?		
Does the wheelchair user have any pressure sores?	Yes <input type="checkbox"/> No <input type="checkbox"/>	
Describe (location and grade)		
How would you rate your satisfaction with your wheelchair from 1-5? (1 is not satisfied and 5 is very satisfied)	Rate:	
Comment:		

3. Wheelchair and cushion check

Is the wheelchair in good working order and safe to use?	Yes <input type="checkbox"/> No <input type="checkbox"/>	
Is the cushion in good working order and safe to use?	Yes <input type="checkbox"/> No <input type="checkbox"/>	
If no for either, what is the problem?		

4. Fitting check

Does the wheelchair fit correctly?	Yes <input type="checkbox"/> No <input type="checkbox"/>	
If no – what is the problem?		
Pressure test level (1 = safe, 2 = warning, 3 = unsafe) (if user at risk of developing a pressure sore)	Left:	
	Right:	
Is the wheelchair user sitting upright comfortably when still, moving, and through the day?	Yes <input type="checkbox"/> No <input type="checkbox"/>	
If no – what is the problem?		

Wheelchair follow up form

This form is for recording information from a follow up visit.

I. Wheelchair user information

Wheelchair user name: Daarun Number: _____

Date of fitting: _____ Date of follow up: _____

Name of person carrying out follow up: _____

Follow up carried out at: User's home Wheelchair service centre Other: _____

2. Interview

**Record action
to be taken:**

Are you using your wheelchair as much as you would like?	Yes <input type="checkbox"/> No <input type="checkbox"/>	
If no – why not?		
Do you have any problems using your wheelchair?	Yes <input type="checkbox"/> No <input type="checkbox"/>	
If yes – what are the problems?		
Do you have any questions about using your wheelchair?	Yes <input type="checkbox"/> No <input type="checkbox"/>	
If yes – what questions? Is further training needed?		
Does the wheelchair user have any pressure sores?	Yes <input type="checkbox"/> No <input type="checkbox"/>	
Describe (location and grade)		
How would you rate your satisfaction with your wheelchair from 1-5? (1 is not satisfied and 5 is very satisfied)	Rate:	
Comment:		

3. Wheelchair and cushion check

Is the wheelchair in good working order and safe to use?	Yes <input type="checkbox"/> No <input type="checkbox"/>	
Is the cushion in good working order and safe to use?	Yes <input type="checkbox"/> No <input type="checkbox"/>	
If no for either, what is the problem?		

4. Fitting check

Does the wheelchair fit correctly?	Yes <input type="checkbox"/> No <input type="checkbox"/>	
If no – what is the problem?		
Pressure test level (1 = safe, 2 = warning, 3 = unsafe) (if user at risk of developing a pressure sore)	Left:	
	Right:	
Is the wheelchair user sitting upright comfortably when still, moving, and through the day?	Yes <input type="checkbox"/> No <input type="checkbox"/>	
If no – what is the problem?		

Wheelchair follow up form

This form is for recording information from a follow up visit.

1. Wheelchair user information

Wheelchair user name: Talha Number: _____

Date of fitting: _____ Date of follow up: _____

Name of person carrying out follow up: _____

Follow up carried out at: User's home Wheelchair service centre Other: _____

2. Interview

**Record action
to be taken:**

Are you using your wheelchair as much as you would like?	Yes <input type="checkbox"/> No <input type="checkbox"/>	
If no – why not?		
Do you have any problems using your wheelchair?	Yes <input type="checkbox"/> No <input type="checkbox"/>	
If yes – what are the problems?		
Do you have any questions about using your wheelchair?	Yes <input type="checkbox"/> No <input type="checkbox"/>	
If yes – what questions? Is further training needed?		
Does the wheelchair user have any pressure sores?	Yes <input type="checkbox"/> No <input type="checkbox"/>	
Describe (location and grade)		
How would you rate your satisfaction with your wheelchair from 1-5? (1 is not satisfied and 5 is very satisfied)	Rate:	
Comment:		

3. Wheelchair and cushion check

Is the wheelchair in good working order and safe to use?	Yes <input type="checkbox"/> No <input type="checkbox"/>	
Is the cushion in good working order and safe to use?	Yes <input type="checkbox"/> No <input type="checkbox"/>	
If no for either, what is the problem?		

4. Fitting check

Does the wheelchair fit correctly?	Yes <input type="checkbox"/> No <input type="checkbox"/>	
If no – what is the problem?		
Pressure test level (1 = safe, 2 = warning, 3 = unsafe) (if user at risk of developing a pressure sore)	Left:	
	Right:	
Is the wheelchair user sitting upright comfortably when still, moving, and through the day?	Yes <input type="checkbox"/> No <input type="checkbox"/>	
If no – what is the problem?		

B.14: Putting it all together

Prepare a 10 minute presentation for the whole group.

The presentation should include the following.

1. Information gained from the assessment:

- the wheelchair user's goals (why he/she wants a wheelchair);
- his/her physical needs;
- his/her lifestyle needs;
- whether he/she has an existing wheelchair – and whether this wheelchair is meeting his/her needs;
- presence, risk of or history of pressure sores;
- method of pushing;
- sitting posture without support;
- results of the pelvis and hip posture screening;

2. Wheelchair and cushion prescribed:

- type of wheelchair
- type of cushion
- any postural support devices that were prescribed.

3. Fitting:

- any problems that were identified at fitting and needed to be resolved – and if so, how these were resolved.

4. User training:

- what did the wheelchair user and the group decide should be covered in user training?

5. Wheelchair user's feedback:

- after receiving the wheelchair – did the wheelchair user have any comments/ feedback?

6. Maintenance and repairs:

- after receiving the wheelchair – what maintenance needs to be carried out and how often?
- what to do when a wheelchair or cushion needs repair?

7. Follow up plan:

- what arrangements have been made for follow up?

For more information, contact.

World Health Organization
20, Avenue Appia
CH-1211 Geneva 27
Switzerland

Tel.: (+ 41 22) 791-2715
Fax: (+ 41 22) 791-4874

[www.who.int/disabilities/en/
dar@who.int](http://www.who.int/disabilities/en/dar@who.int)

ISBN 978 92 4 150347 1



9 789241 503471